

**LEARNING MATERIAL OF  
HYDRAULIC MACHINE & INDUSTRIAL FLUID  
POWER**

**PREPARED BY – ER. SUBHASHMITA JENA**

**&**

**ER. MANAS RANJAN BEHERA**

# CHAPTER:1

**Q. What is reaction turbine**

**Ans:** If at the inlet of turbine the water possess kinetic energy as well as pressure energy then it is known as reaction turbine.

**Q. Describe construction and working of Kaplan turbine [2013(s)]**

**Ans:**

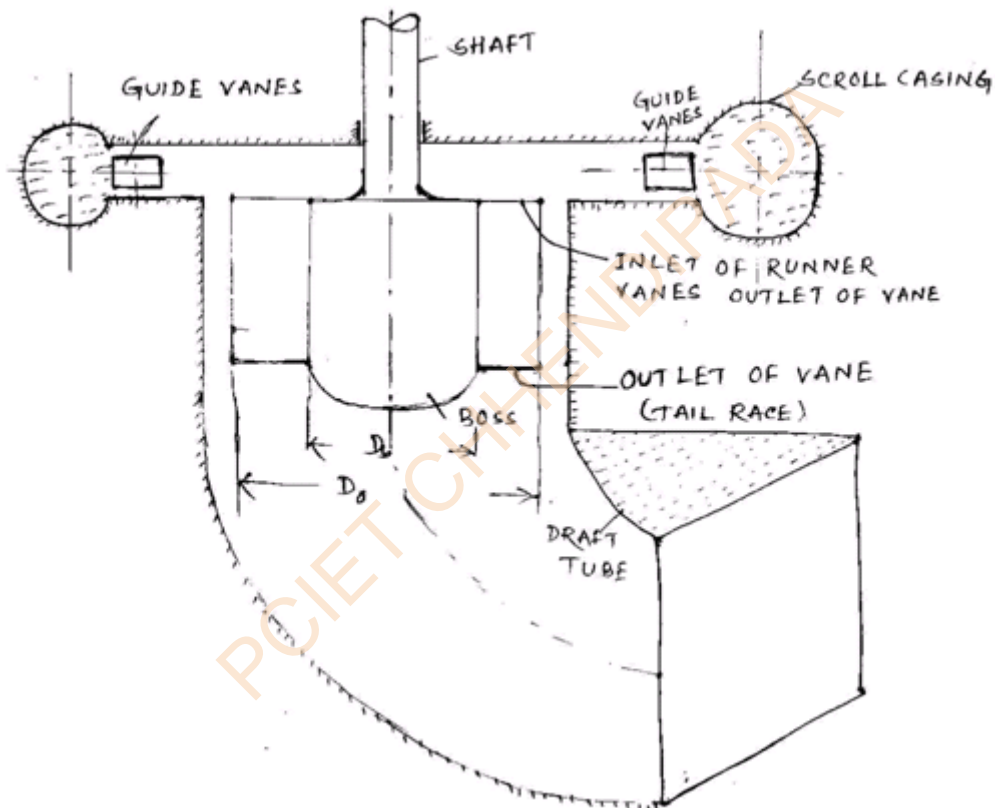

**Working:-**

A propeller turbine is quite suitable when the load on the turbine remains constant. At part load its efficiency is very low, since the blades are fixed, the water enters with shock (at part load) and eddies are formed which reduces the efficiency. This defect of the propeller turbine is removed in Kaplan turbine. In a Kaplan turbine the runner blades are adjustable and can be rotated about pivots fixed to the boss of the runner. The blades are adjusted

automatically by servo mechanism, so that at all loads the flow enters them without shock. Thus, a high efficiency is maintained even at part load. The servomotor cylinder is usually accommodated in the hub.

Construction:

The Kaplan turbine has purely axial flow usually it has 4 to 6 blades having no outside rim. It is also known as a variable pitch propeller turbine since the pitch of the turbine can be changed because of adjustable vanes. The Kaplan turbine behaves like a propeller turbine at full-load condition.

The scroll casing, guide mechanism and draft tube are similar to that in the Francis turbine. The shape of runner blades is different from that of Francis turbine. The blades of Kaplan turbine are made of stainless steel.

Kaplan turbine, like every propeller turbine, is a high speed turbine & is used for smaller heads, as the speed is high, the number of runner vanes is small.

**Q. Classify turbine in terms of head of water**

<b>Ans:Sl.No.</b>	<b>Head of water in meters</b>	<b>Types of turbine</b>
1.	0 to 25	Kaplan or Francis (Preferably Kaplan)
2.	25 to 50	Kaplan or Francis (Preferably Francis)
3.	50 to 150	Francis
4.	150- to 250	Francis or pelton (Preferably Francis)
5.	250 to 300	Francis or Pelton (Preferably Pelton)
6.	Above 300	Pelton

**Q. A pelton wheel has a mean bucket speed of 25 m/s with a jet of water flowing at a rate of 1.2 m<sup>3</sup>/s under a head of 250 m. the bucket deflects through an angle of 170°. Calculate the power delivered to runner and hydraulic efficiency**

**Ans:**  $u = u_1 = u_2 = 25 \text{ m/s}$

Discharge,  $Q = 1.2 \text{ m}^3/\text{s}$

Head,  $H = 250 \text{ m}$

Angle of deflection = 170°

Angle,  $\theta = 180^\circ - 170^\circ = 10^\circ$

Assume  $C_v = 0.98$

Velocity of jet,  $V_1 = C_v \sqrt{2gh} = 0.98 \sqrt{2 \times 9.81 \times 250} = 68.64 \text{ m/s}$

$V_{r1} = V_1 - u_1 = 68.64 - 25 = 43.64 \text{ m/s}$ ,  $V_{r2} = v_{r1} = 43.64 \text{ m/s}$

$V_{w1} = v_1 = 68.64 \text{ m/s}$

$V_{w2} = V_{r2} \cos \phi - u_2 = 43.64 \times \cos 10^\circ - 25 = 17.99 \text{ m/s}$

Work done by jet per second on the runner

$$= \rho Q (V_{w1} + V_{w2}) \times r$$

$$= 1000 \times 1.2 \times (68.64 + 17.99) \times 25 = 2598900 \text{ Nm/s}$$

$$\text{Power given to turbine} = \frac{\text{work done by jet per sec}}{1000} \text{ kw}$$

$$= \frac{2598900}{1000} = 2598.9 \text{ kw}$$

$$\text{Hydraulic efficiency } \eta_h = \frac{2(V_{w1} + V_{w2}) \times r}{V_1^2}$$

$$= \frac{2(68.64 + 17.99) \times 25}{(68.64)^2} = 0.92 \text{ or } 92 \%$$

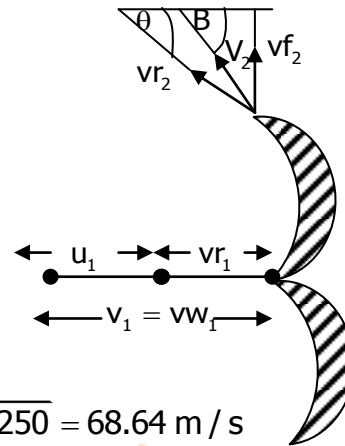

**Q. In an inward flow reaction turbine of inner and outer diameters of wheel as 0.75 m and 1.25 m respectively the vanes are radial at inlet and discharge is radial at outlet and water enters the vanes at an angle of  $12^\circ$ . If the velocity of flow is 3.5 m/s. find speed of wheel and vane angle at outlet.**

**Ans:** Outer diameter ( $D_1$ ) = 1.25 m

Inner diameter (= 0.75 m

Vaness are radial at inlet

$\theta = 90^\circ$  and  $Vf_1 Vr_1, Vf_1 = Vf_2 = 3.5$  m/s

Discharge is radial at outlet.

$\beta = 90^\circ$   $Vw_2 = 0$

Vane angle at inlet,  $\alpha = 12^\circ$

$$\tan \alpha = \frac{Vf_1}{u_1} \Rightarrow u_1 = \frac{Vf_1}{\tan \alpha} = \frac{3.5}{\tan 12^\circ} = 16.43 \text{ m/s}$$

$$u_1 = \frac{\pi D_1 N}{60}$$

$$\Rightarrow 16.43 = \frac{\pi \times 1.25 \times N}{60}$$

$$\Rightarrow N = \frac{60 \times 16.43}{\pi \times 1.25} = 251 \text{ rpm}$$

$$u_2 = \frac{\pi D_2 N_2}{60} = \frac{\pi \times 0.75 \times 251}{60} = 9.85 \text{ m/s}$$

Vane angle at outlet ( $\theta$ )

$$\tan \theta = \frac{Vf_2}{u_2} \Rightarrow \theta = \tan^{-1} \left( \frac{Vf_2}{u_2} \right) = \tan^{-1} \left( \frac{3.5}{9.85} \right) = 19.8^\circ \text{ or } 19^\circ 47'$$



**Q. A pelton wheel turbine produces 20 MW while running at 700 rpm under the head of 1700 m. Calculate**

**(i) Least diameter of jet**

**(ii) Mean diameter of runner**

**(iii) Number of bucket**

**Ans:** S.P. = 20 MW =  $20 \times 10^6$  W

N = 700 r.p.m.

H = 1700 m

According to design of pelton wheel turbine, Jet ratio  $m = D/d = 12$  where D = Dia of runner and d = dia of jet

$$u = d \times \sqrt{2gH} = 0.43 \times \sqrt{2 \times 9.81 \times 1700} = 78.5 \text{ m / s}$$

$$u = \frac{\pi DN}{60}$$

$$\Rightarrow D = \frac{u \times 60}{\pi \times N} = \frac{78.5 \times 60}{\pi \times 700} = 2.14 \text{ m}$$

$$m = \frac{D}{d} = 12 \Rightarrow d = \frac{D}{12} = \frac{2.14}{12} = 0.18 \text{ m}$$

$$\text{Number of bucketz} = 15 + \frac{D}{2d} = 15 + \frac{2.14}{2 \times 0.18} = 20.94 \text{ say } 21$$

(i) d = least diameter of jet = 0.18 m

(ii) D = diameter of runner = 2.14 m

(iii) Number of buckets = 21

### Q. What is a reaction turbine ?

**Ans:** In a reaction turbine the energy available at the inlet of turbine is kinetic energy and pressure energy. In reaction turbine the blades are fully enclosed in an airtight casing and is not exposed to atmosphere.

Example :- francis turbine

### Q. Classify water turbines :

**Ans:** 1. According to type of energy at inlet

(a) Impulse turbine (b) Reaction turbine

2. According to direction of flow through runner

(a) Tangential flow turbine (b) Radial flow turbine

(c) Axial flow turbine (d) Mixed flow turbine

3. According to head at inlet of turbine

(a) High head turbine (b) Medium head turbine

(c) Low head turbine

4. According to specific speed of turbine
- (a) Low specific speed turbine
  - (b) Medium specific speed turbine
  - (c) High specific speed turbine

**Q. Give layout of hydroelectric power plant.**

**Ans: High Head Power Plants**

These types of plants work under heads 100 m and above. Water is usually stored up in lakes on high mountains during the rainy season or during the reason when the snow melts. The rate of flow should be such that water can last throughout the year.

Figure shows high head power plant layout. Surplus water discharged by the spillway cannot endanger the stability of the main dam by erosion because they are separated. The tunnel through the mountain has a surge chamber excavated near the exit. Flow is controlled by head gates at the tunnel intake, butterfly valves at the top of the penstocks, and gate valves at the turbines. This type of site might also be suitable for an underground station.

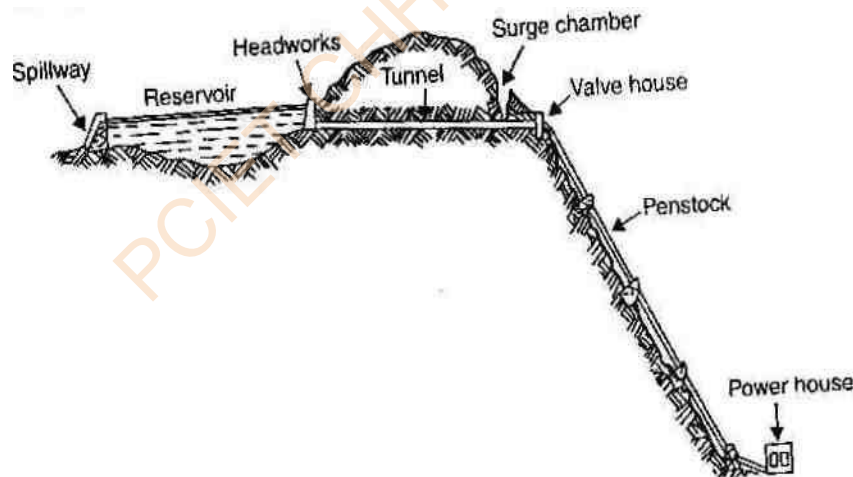

High head power plant layout. The main dam, spillway, and powerhouse stand at widely separated locations. Water flows from the reservoir through a tunnel and penstock to the turbines.

The pelton wheel is the common primemover used in high head power plants.

## Medium Head power plants

When the operating head of water lies between 30 to 100 metres, the power plant is known as medium head power plant. This type of plant commonly uses Francis turbines. The forebay provided at the beginning of the penstock serves as water reservoir. In such plants, the water is generally carried in open canals from main reservoir to the forebay and then to the power house through the penstock. The forebay itself works as a surge tank in this plant.

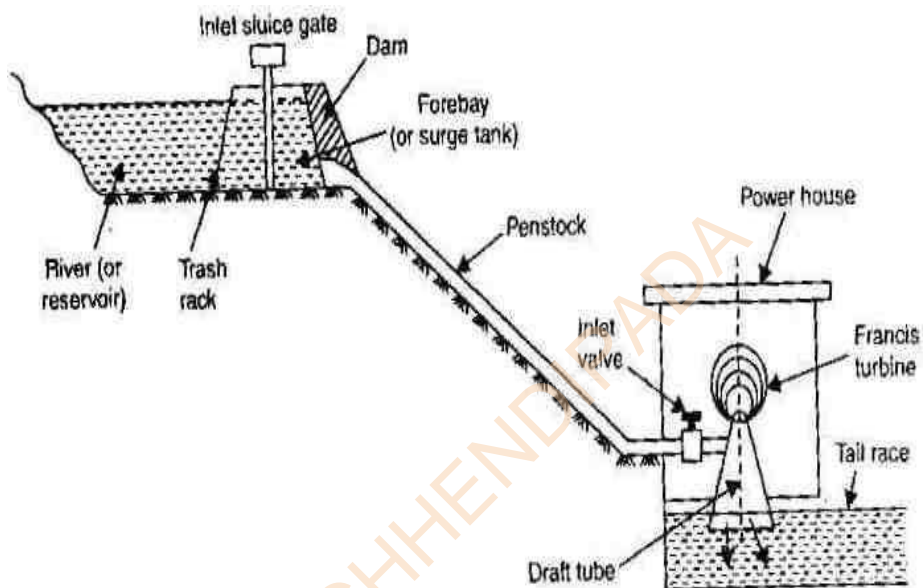

## Low Head Power Plants

Figure shows these plants usually consist of a dam across a river. A sideways stream diverges from the river at the dam. Over this stream the power house is constructed. Later this channel joins the river further downstream. This type of plant uses vertical shaft Francis turbine or Kaplan turbine.



### 23.4. Comparison between Impulse Turbine and Reaction Turbine

Following are the few points of comparison between an impulse turbine and a reaction turbine.

S. No.	Impulse turbine	Reaction turbine
1.	The steam flows through the nozzles and impinges on the moving blades.	The steam flows first through guide mechanism and then through the moving blades.
2.	The steam impinges on the buckets with kinetic energy.	The steam glides over the moving vanes with pressure and kinetic energy.
3.	The steam may or may not be admitted over the whole circumference.	The steam must be admitted over the whole circumference.
4.	The steam pressure remains constant during its flow through the moving blades.	The steam pressure is reduced during its flow through the moving blades.
5.	The relative velocity of steam while gliding over the blades remains constant (assuming no friction).	The relative velocity of steam while gliding over the moving blades increases (assuming no friction).
6.	The blades are symmetrical.	The blades are not symmetrical.
7.	The number of stages required are less for the same power developed.	The number of stages required are more for the same power developed.

## ► 18.6 PELTON WHEEL (OR TURBINE)

The Pelton wheel or Pelton turbine is a tangential flow impulse turbine. The water strikes the bucket along the tangent of the runner. The energy available at the inlet of the turbine is only kinetic energy. The pressure at the inlet and outlet of the turbine is atmospheric. This turbine is used for high heads and is named after L.A. Pelton, an American Engineer.

Fig. 18.1 shows the layout of a hydroelectric power plant in which the turbine is Pelton wheel. The water from the reservoir flows through the penstocks at the outlet of which a nozzle is fitted. The nozzle increases the kinetic energy of the water flowing through the penstock. At the outlet of the nozzle, the water comes out in the form of a jet and strikes the buckets (vanes) of the runner. The main parts of the Pelton turbine are :

1. Nozzle and flow regulating arrangement (spear),
2. Runner and buckets,
3. Casing, and
4. Breaking jet.

**1. Nozzle and Flow Regulating Arrangement.** The amount of water striking the buckets (vanes) of the runner is controlled by providing a spear in the nozzle as shown in Fig. 18.2. The spear is a conical needle which is operated either by a hand wheel or automatically in an axial direction depending upon the size of the unit. When the spear is pushed forward into the nozzle the amount of water striking the runner is reduced. On the other hand, if the spear is pushed back, the amount of water striking the runner increases.

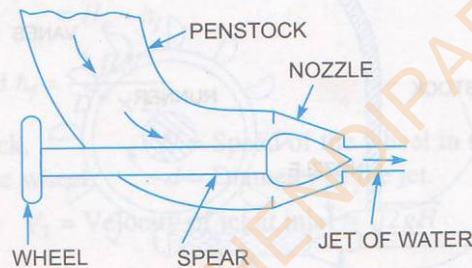

Fig. 18.2 Nozzle with a spear to regulate flow.

**2. Runner with Buckets.** Fig. 18.3 shows the runner of a Pelton wheel. It consists of a circular disc on the periphery of which a number of buckets evenly spaced are fixed. The shape of the buckets is of a double hemispherical cup or bowl. Each bucket is divided into two symmetrical parts by a dividing wall which is known as splitter.



The jet of water strikes on the splitter. The splitter divides the jet into two equal parts and the jet comes out at the outer edge of the bucket. The buckets are shaped in such a way that the jet gets deflected through  $160^\circ$  or  $170^\circ$ . The buckets are made of cast iron, cast steel bronze or stainless steel depending upon the head at the inlet of the turbine.

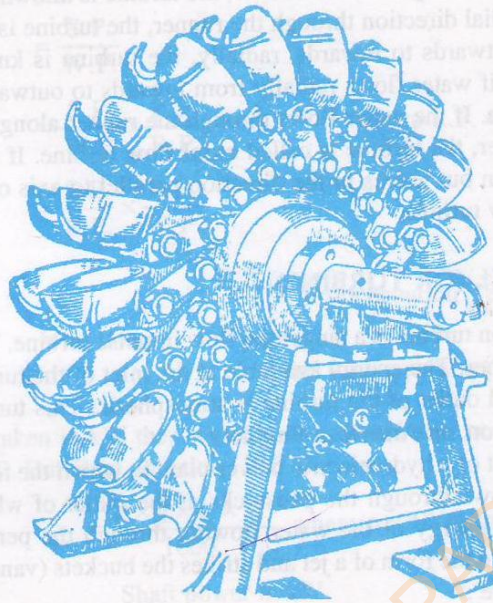

Fig. 18.3 Runner of a pelton wheel.

**3. Casing.** Fig. 18.4 shows a Pelton turbine with a casing. The function of the casing is to prevent the splashing of the water and to discharge water to tail race. It also acts as safeguard against accidents. It is made of cast iron or fabricated steel plates. The casing of the Pelton wheel does not perform any hydraulic function.

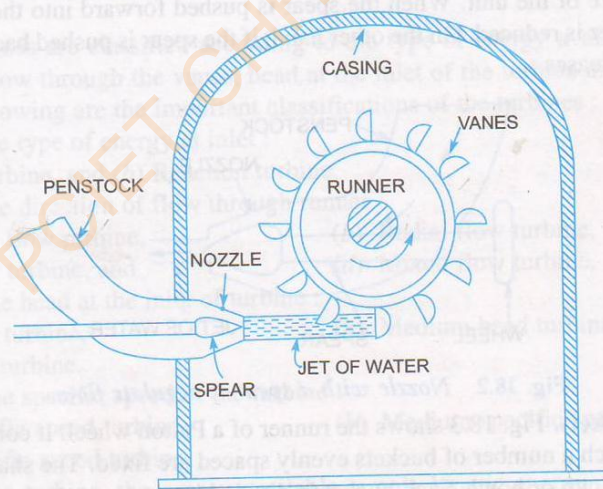

Fig. 18.4 Pelton turbine.

**4. Breaking Jet.** When the nozzle is completely closed by moving the spear in the forward direction, the amount of water striking the runner reduces to zero. But the runner due to inertia goes on revolving for a long time. To stop the runner in a short time, a small nozzle is provided which directs the jet of water on the back of the vanes. This jet of water is called breaking jet.



## ► 18.7 RADIAL FLOW REACTION TURBINES

Radial flow turbines are those turbines in which the water flows in the radial direction. The water may flow radially from outwards to inwards (*i.e.*, towards the axis of rotation) or from inwards to outwards. If the water flows from outwards to inwards through the runner, the turbine is known as inward radial flow turbine. And if the water flows from inwards to outwards, the turbine is known as outward radial flow turbine.

Reaction turbine means that the water at the inlet of the turbine possesses kinetic energy as well as pressure energy. As the water flows through the runner, a part of pressure energy goes on changing into kinetic energy. Thus the water through the runner is under pressure. The runner is completely enclosed in an air-tight casing and casing and the runner is always full of water.

**18.7.1 Main Parts of a Radial Flow Reaction Turbine.** The main parts of a radial flow reaction turbine are :

1. Casing,
2. Guide mechanism,
3. Runner, and
4. Draft-tube.

**1. Casing.** As mentioned above that in case of reaction turbine, casing and runner are always full of water. The water from the penstocks enters the casing which is of spiral shape in which area of cross-section of the casing goes on decreasing gradually. The casing completely surrounds the runner of the turbine. The casing as shown in Fig. 18.10 is made of spiral shape, so that the water may enter the runner at constant velocity throughout the circumference of the runner. The casing is made of concrete, cast steel or plate steel.

**2. Guide Mechanism.** It consists of a stationary circular wheel all round the runner of the turbine. The stationary guide vanes are fixed on the guide mechanism. The guide vanes allow the water to strike the vanes fixed on the runner without shock at inlet. Also by a suitable arrangement, the width between two adjacent vanes of guide mechanism can be altered so that the amount of water striking the runner can be varied.

**3. Runner.** It is a circular wheel on which a series of radial curved vanes are fixed. The surface of the vanes are made very smooth. The radial curved vanes are so shaped that the water enters and leaves the runner without shock. The runners are made of cast steel, cast iron or stainless steel. They are keyed to the shaft.

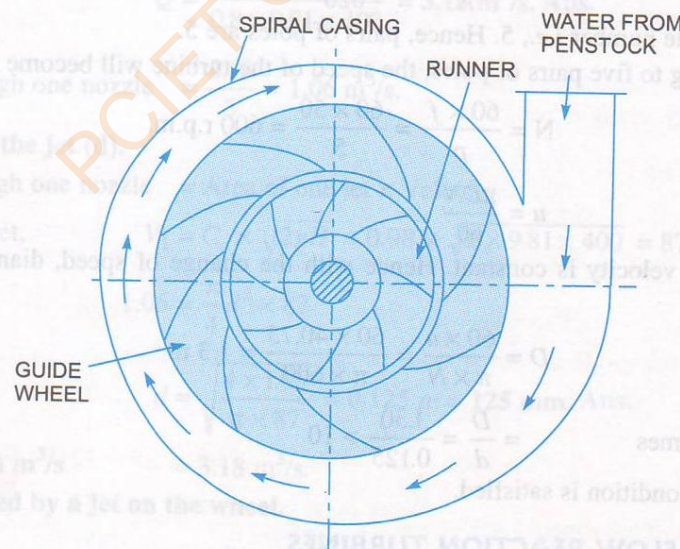

Fig. 18.10 Main parts of a radial reaction turbines.

**4. Draft-tube.** The pressure at the exit of the runner of a reaction turbine is generally less than atmospheric pressure. The water at exit cannot be directly discharged to the tail race. A tube or pipe of gradually increasing area is used for discharging water from the exit of the turbine to the tail race. This tube of increasing area is called draft tube.

## CHAPTER:2

### Q. What is Cavitation.

**Ans:** Cavitation is defined as the phenomenon of formation of vapour bubbles of flowing liquid in a region where the pressure of liquid falls below its vapour pressure and sudden collapsing of these vapour bubbles into region of high pressure.

### Q. Differentiate between centrifugal pump and reciprocating pump.

<b>Centrifugal Pump.</b>	<b>Reciprocating Pump.</b>
1. Simple in construction because of less number of parts	1. Complicated in construction because of more number of parts
2. total weight of pump is less for a given discharge	2. Total weight of pump is more for a given discharge
3. It requires less space.	3. It requires more space.
4. It has less wear and tear.	4. It has more wear and tear.
5. It's maintenance cost is low.	5. Its maintenance cost is high.
6. It can handle dirty water.	6. It can't handle dirty water
7. It does not require air vessels.	7. It requires air vessels.
8. It is suitable for large discharge and smaller heads	8. It is suitable for less discharge and higher heads

### Q. Draw a neat sketch of a centrifugal pump and explain its working.

[2013(s), 4-a]

#### **Ans:Centrifugal pump**

- i. The hydraulic machine which convert the mechanical energy is converted, into pressure energy by means of centrifugal force acting on the fluid is known as centrifugal pump.
- ii. A centrifugal pump is a roto dynamic type pump in which pressure energy is provided to the liquid with the help of centrifugal action.

#### **Main parts of a centrifugal pump:**

- i. The impeller is a device which used in a centrifugal pump the no. of vanes are filled over the circumference of the impeller which is fitted on the shaft of the motor. The main function is the impeller which is converted the striking of water into rotary motion.

ii. The function of casing the same as that the turbine casing there are different of casing are used in case of centrifugal pump. The main function of casing is :

- To prevent the accident
- To avoid to splash out the water
- to increasing the pressure in the water of the chamber.

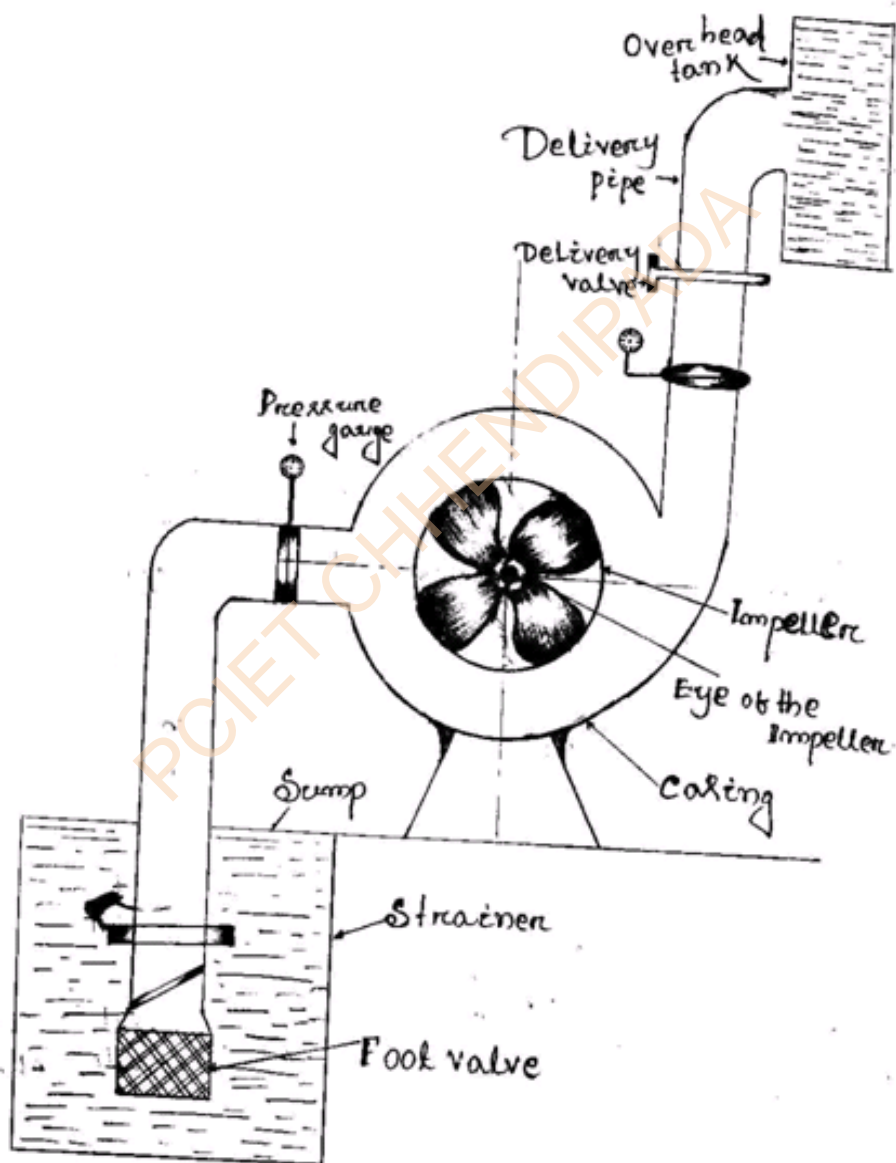

### iii. Suction pipe

The suction pipe one type of connection in between the water sump and the impeller. The one end is deep in the supply of water and the other end is connected to the impeller in proper connection.

### iv. Foot valve/Strainer

- A foot valve which is a non return valve or one way type valve is fitted in the lower end of the suction pipe.
- the foot valve open only the upward direction.
- A strainer is also fitted with lower end of the suction pipe from purify of the water

### v. Delivery pipe

A pipe whose one end is connected to the outlet of the pump and other end delivers the water at a required height is known as delivery pipe.

### Working:-

In case of hydraulic ram the supply tank is fitted with chamber through supply pipe with inlet valve. When the water supply tank through the supply pipe to the chamber the inlet valve open. The continuously supply of water to the chamber the pressure in side the chamber is gradually increase by the water. When a water rise up in the chamber the wastes valve is operated which is closed to it's open according to the figure. When the wastes valve is close suddenly increased the pressure in side the chamber.

$$= \frac{\pi D_1 N}{60}$$

$D_2$  = Diameter of impeller at outlet.

$U_2$  = Tangential velocity of impeller at outlet =  $\frac{\pi D_2 N}{60}$

$V_1$  = Absolute velocity of water at inlet.

$V_{r1}$  = Relative velocity of water at inlet.

$\alpha$  = angle made by absolute velocity ( $V_1$ ) at inlet with the direction of motion of vane.



$\theta$  = Angle made by relative velocity ( $V_{r1}$ ) at inlet with the direction of motion of vane and  $V_{r2}$ ,  $\beta$  and  $\phi$  are the corresponding values at outlet. As the water enters the impeller radially which means the absolute velocity of water at inlet in the radial direction and hence angle  $\alpha = 90^\circ$  and  $V_{w1} = 0$ .

A centrifugal pump is the reverse of a radially inward flow reaction turbine. But in case of a radials of the water striking per second is given by equation as

$$= \frac{1}{g} [V_{w1} u_1 - V_{w2} u_2]$$

$\therefore$  work done by the impeller on the water per second per unit weight of water striking per second.

$$= -[\text{Work done case of turbine}]$$

$$= -\left[ \frac{1}{g} (V_{w1} u_1 - V_{w2} u_2) \right] = \frac{1}{g} [V_{w2} u_2 - V_{w1} u_1]$$

$$= \frac{1}{g} V_{w2} u_2 \quad (\because V_{w1} = 0 \text{ here})$$

Work done by impeller on water per second

$$= \frac{W}{g} V_{w2} u_2$$

Where  $W$  = Weight of water =  $\rho \times g \times Q$

Where  $Q$  = Volume of water

And  $Q$  = Area  $\times$  Velocity of flow =  $\pi D_1 B_1 \times V_{f1}$

$$= \pi D_2 B_2 \times C_{f2}$$

Where  $B_1$  and  $B_2$  are width of impeller at inlet and outlet and  $V_{f1}$  and  $V_{f2}$  are velocities of flow at inlet and outlet

Equation gives the head imparted to the water by the impeller or energy given by impeller s water per unit weight per second.



**Q. With a neat sketch explain in brief the working of a single acting and double acting reciprocating pump.**

**Ans:i. Single acting Reciprocating pump.**

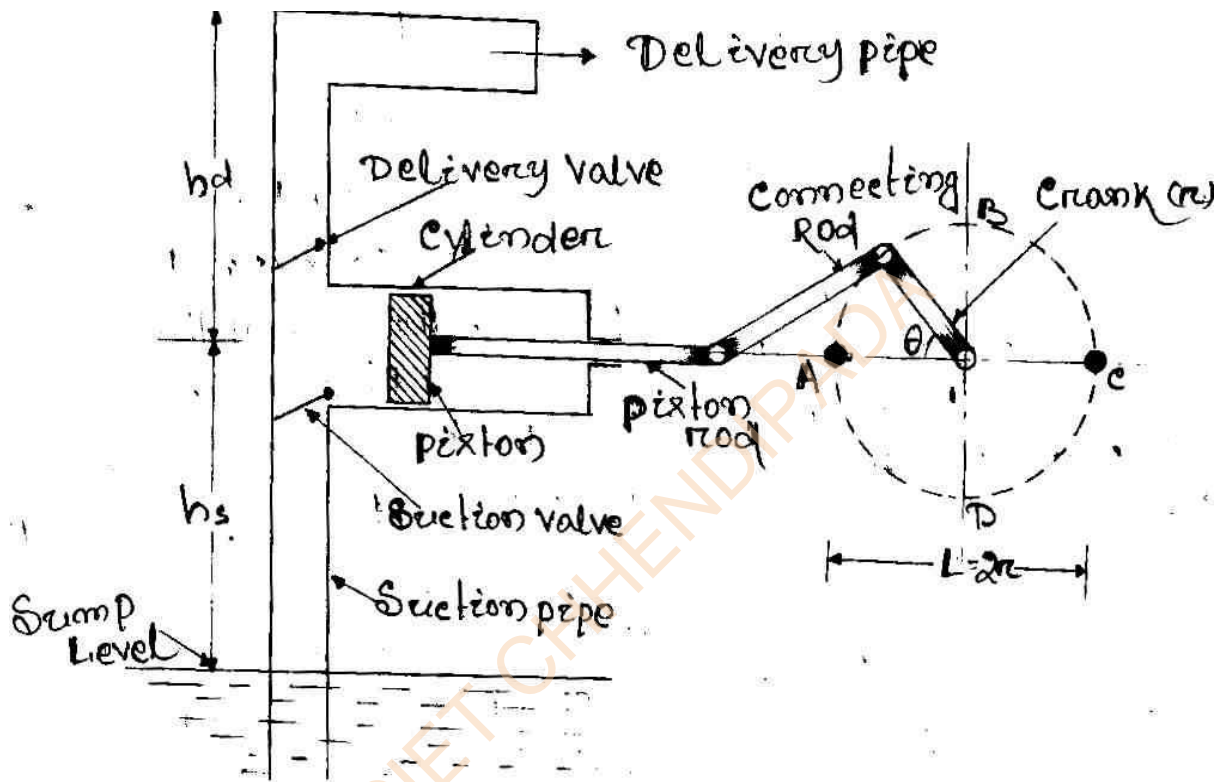

**Working:-**

A single acting reciprocating pump, which consists of a piston which moves forwards and backwards in a close fitting cylinder. The movement of the piston is obtained by connecting the piston rod to crank by means of a connecting rod. The crank is rotated by means of an electric motor. Suction and delivery pipe with suction valve and delivery valve are connected to the cylinder. The suction and delivery valves are (one way valve) non return valves, which allow the water to flow in one direction only. Suction valves allow water from suction pipe to the cylinder which delivery valve allows water from cylinder to delivery pipe only.

When crank starts rotating, the piston moves to and from in the cylinder. When crank is at 'A', the piston is at the extreme left position in the cylinder. As the crank is rotating from 'A' to 'C' the piston is moving towards right in the cylinder.

The movement of the piston towards right creates a partial vacuum in the cylinder. But on the surface of the liquid in the sump atmospheric pressure is acting, which is more than the pressure inside the cylinder. Thus the liquid is forced in the suction pipe from the sump.

## ii. Double – acting Reciprocating pump

In case of double acting pump, the water is acting on both sides of the piston. Thus we required two suction pipes and two delivery pipes double-acting pump. When there is a suction stroke on one side of the piston, there is at the same time a delivery stroke on the other side of the piston. Thus for one complete revolution of the crank there are two delivery strokes and water is delivered to the pipes by the pump during these two delivery strokes.

Let  $D$  = Diameter of the piston

$d$  = Diameter of the piston rod

Area on one side of the piston.

$$\therefore A = \frac{\pi}{4} D^2$$

Area of the other side of the piston

$$\therefore A_1 = \frac{\pi}{4} D^2 - \frac{\pi}{4} d^2 = \frac{\pi}{4} (D^2 - d^2)$$

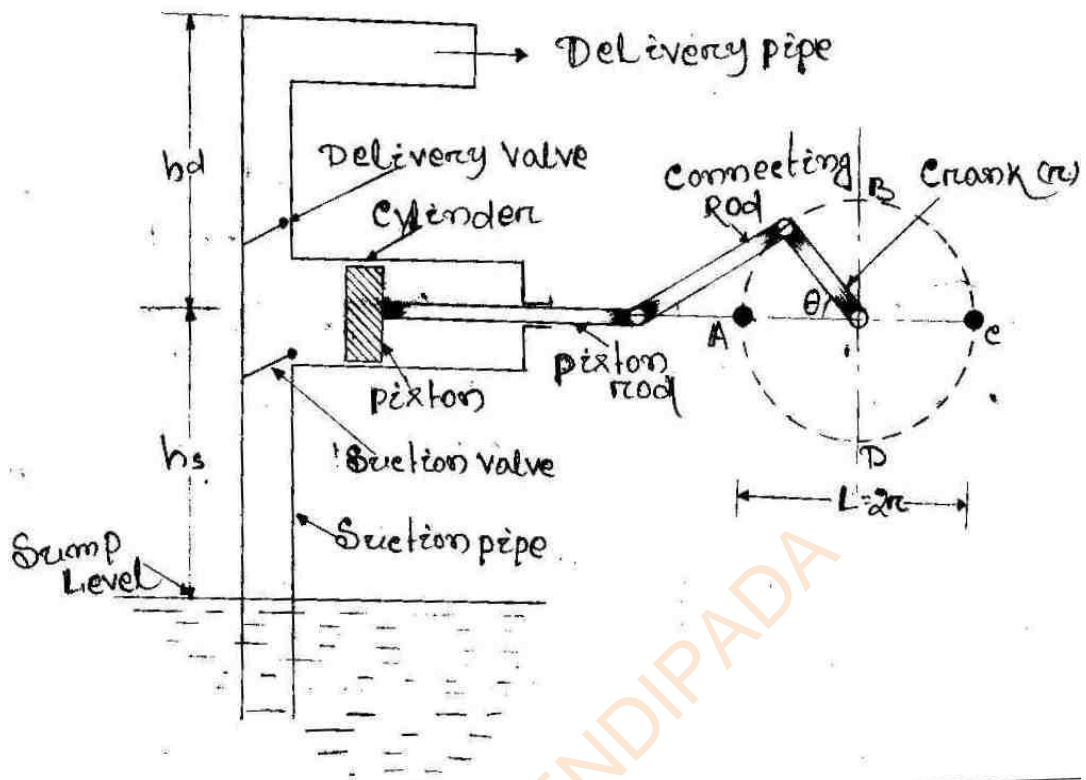

- Q. A centrifugal pump having outer diameter twice the inner diameter running at 1100 rpm works against a head of 180 m. the velocity of flow through the impeller is constant at 3 m/s. the vanes are set back at an angle of  $30^\circ$  at outlet. If outer diameter of impeller is 60 m and width at outlet is 6 cm. Determine (i) Vane angle at inlet (ii) Work done/sec and (iii) manometric efficiency.**

**Ans:** Let  $D_1$  = inner diameter

$D_2$  = Outer diameter

$D_2 = 2D_1$  (given)

Speed,  $N = 1100$  rpm.

Head,  $H_m = 180$  m

$V_{f1} = V_{f2} = 3$  m/s

Vane angle at outlet  $\theta = 30^\circ$



$$\text{Discharge, } Q = \pi \times 0.6 \times 0.6 \times 3 = 0.34 \text{ m}^3 / \text{s}$$

Vane angle at inlet ( $\theta$ )

$$\tan \theta = \frac{V_{f1}}{u_1} = \frac{3}{17.27} = 0.174$$

$$\Rightarrow \theta = \tan^{-1}(0.174) = 9.87^\circ \text{ or } 9^\circ 52'$$

$$\text{Again } \tan \theta = \frac{V_{f2}}{u_2 - V_{w2}} \Rightarrow \tan 30^\circ = \frac{3}{34.54 - V_{w2}}$$

$$\Rightarrow 0.577 = \frac{3}{34.54 - V_{w2}} \Rightarrow 0.577(34.54 - V_{w2}) = 3$$

$$\Rightarrow 34.54 - V_{w2} = \frac{3}{0.577} = 5.2$$

$$\Rightarrow V_{w2} = 34.54 - 5.2 = 29.34 \text{ m/s.}$$

Workdone by impeller on water per second

$$\begin{aligned} &= \frac{W}{g} \times V_{w2} u_2 = \frac{\rho \times g \times Q}{g} \times V_{w2} u_2 = \rho \times Q \times V_{w2} u_2 \\ &= 1000 \times 0.34 \times 29.34 \times 34.54 = 344557.22 \text{ Nm/s} \end{aligned}$$

$$\text{Manometric efficiency, } \eta_{\text{man}} = \frac{gH_m}{V_{w2} u_2}$$

$$= \frac{9.81 \times 180}{29.34 \times 34.54} = 1.74$$

**Q. A centrifugal pump having outer diameter twice the inner diameter running at 1100 rpm. Works against a head of 180 m. the velocity of flow through the impeller is constant at 3 m/s. The vanes are set back at an angle of  $30^\circ$  at outlet if the outer diameter of impeller is 60 cm and width at outlet is 6 cm.**

- Determine**
- (i) Vane angle at inlet**
  - (ii) Work done/se**
  - (iii) Manometri efficiency**

**Ans:** Speed,  $N = 1100$  r.p.m.

Head,  $H_m = 180$  m

Velocity of flow,  $V_{f1} = V_{f2} = 3$  m/s

Vane angle at outlet,  $\theta = 30^\circ$

Let  $D_1 =$  Inner diameter of impeller

$D_2 =$  Outer diameter of impeller

$D_2 = 2D_1$  (given)

Outer diameter of impeller

$= 60$  cm  $= 0.6$  m

Inner diameter of impeller

$$D_1 = \frac{D_2}{2} = \frac{0.6}{2} = 0.3 \text{ m}$$

Tangential velocity of impeller at inlet

$$u_1 = \frac{\pi D_1 N}{60} = \frac{\pi \times 0.3 \times 1100}{60} \text{ m/s} = 17.27 \text{ m/s}$$

Tangential velocity of impeller at

$$u_2 = \frac{\pi D_2 N}{60} = \frac{\pi \times 0.6 \times 1100}{60} = 34.54 \text{ m/s}$$

Width at outlet,  $B_2 = 6$  cm  $= 0.06$  m



**Q. Define slip**

**Ans:** Slip is defined as the difference between theoretical discharge and actual discharge.

Slip = theoretical discharge – Actual discharge.

$\eta_{man} =$  The ratio of manometric head to head imparted by impeller to water

$$\eta_{man} = \frac{\text{Manometric head}}{\text{Head imparted by impeller to water}}$$

$$= \frac{H_m}{\frac{V_{w2} \cdot y_2}{g}} = \frac{g H_m}{V_{w2} \cdot y_2}$$

$\eta_m =$  The ratio of power available at impeller to power at stage of pump

$$= \frac{\text{Power at impeller}}{\text{Power at stage}}$$

$$= \frac{W}{g} \times \frac{V_{w2} \cdot y_2}{1000}$$

S.I.P

$\eta_0 =$  ratio of power output of pump to power input

power output = weight of water lifted  $(W) \times \frac{H_m}{1000}$

power input = power supplied by electric motor = S.I.P

$$= \frac{W H_m}{1000}$$

S.I.P

$$\eta_0 = \eta_{man} \times \eta_m$$

$$= \frac{1}{g} [V_{w1} \cdot y_1 - V_{w2} \cdot y_2]$$

$$W = \rho g Q$$

$$Q = \pi D_1 B_1 V_{f1} = \pi D_2 B_2 V_{f2}$$

### Static head

It is the vertical height of centre line of centrifugal pump about water surface in tank.

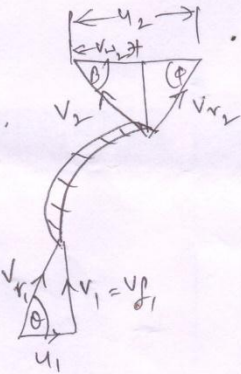

### Delivery head

The vertical distance between the centre line of pump and water surface in tank to which water is delivered.

Static head ( $H_s$ ) = sum of head. Manometric head ( $H_m$ ) - It is defined as head against which a centrifugal pump has to work.

$H_m =$  Head imparted by impeller to water - loss of head in pump.

$$= \frac{V_{w2} \cdot y_2}{g} - \text{loss of head in impeller \& casing}$$

$$= \frac{V_{w2} \cdot y_2}{g} \text{ if loss of pump is zero}$$

$H_m =$  Total head at inlet of pump - " " outlet

$$= \left( \frac{P_0}{\rho g} + \frac{V_0^2}{2g} + z_0 \right) - \left( \frac{P_i}{\rho g} + \frac{V_i^2}{2g} + z_i \right)$$

$$= H_s + H_d + H_{fs} + H_{fd} + \frac{V_d^2}{2g}$$